

2ch Current Loop Supply (with Indication Function)

Model: **SE2D-F**

■ Features

Can be used with a Field Communicator.
(2-wire transmitter power output impedance: 240Ω)

■ Model

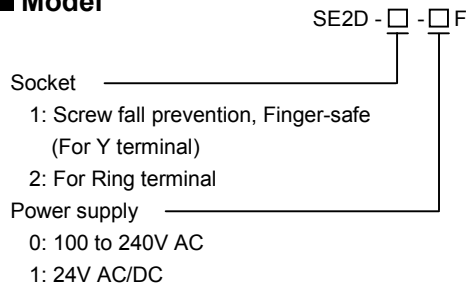

■ How to Order

Specify a model. (e.g.) SE2D-1-0F

Factory Default Value:

CH1 input	4 to 20mA DC
CH2 input	4 to 20mA DC
CH1 output	4 to 20mA DC
CH2 output	4 to 20mA DC

■ Accessories (Sold Separately)

Communication cable to connect console software: CMB-001

■ Input Specifications

DC Current

Input range	Shunt resistor
4 to 20mA DC	50Ω built-in

■ Output Specifications

When the output range lower limit is zero, (even if zero adjustment results in a negative value), the output value will not be negative.

DC Current

Output range	Allowable load resistance	Zero adjustment range	Span adjustment range
4 to 20mA DC	700Ω or less	-5 to 5%	95 to 105%
0 to 20mA DC	700Ω or less	0 to 5%	95 to 105%
0 to 12mA DC	1.2kΩ or less	0 to 5%	95 to 105%
0 to 10mA DC	1.2kΩ or less	0 to 5%	95 to 105%
1 to 5mA DC	2.4kΩ or less	-5 to 5%	95 to 105%

DC Voltage

Output range	Allowable load resistance	Zero adjustment range	Span adjustment range
0 to 1V DC	100Ω or more	0 to 5%	95 to 105%
0 to 5V DC	500Ω or more	0 to 5%	95 to 105%
1 to 5V DC	500Ω or more	-5 to 5%	95 to 105%
0 to 10V DC	1kΩ or more	0 to 5%	95 to 105%

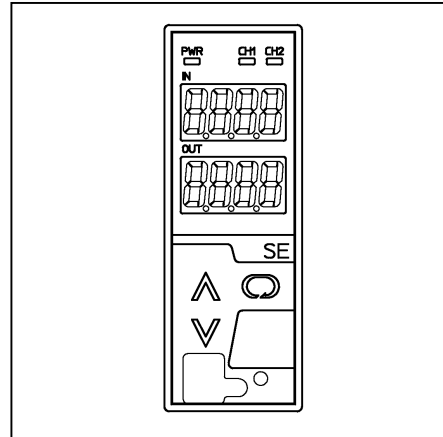

■ Power for 2-wire Transmitter

Output voltage: 24 to 28V DC (When load current is 20mA)
Ripple voltage: Within 200mV DC (When load current is 20mA)
Max. load current: 25mA DC
Output impedance: 240Ω (Can be used with a Field communicator.)

■ Performance

Basic accuracy (at 23°C of ambient temperature)

- Input: Within $\pm 0.1\%$
- Output: Within $\pm 0.1\%$

Indication accuracy: Within Basic accuracy ± 1 digit

Input sampling period: 25ms, 125ms, 250ms (Selectable by the keypad)

Response time: (Selectable by the keypad)

- 65ms (typ.) (0→90%) (Input sampling period: 25ms)
- 225ms (typ.) (0→90%) (Input sampling period: 125ms)
- 425ms (typ.) (0→90%) (Input sampling period: 250ms)

Temperature coefficient: $\pm 0.015\%/^{\circ}\text{C}$ or less

Insulation resistance: 10MΩ or more, at 500V DC
(Input - Output - Power)

Dielectric strength: 2.0kV AC for 1 minute
(Input - Output - Power)

■ General Structure

Case: Flame-resistant resin Color: Light gray

Front panel: Membrane sheet

Setting : Using front keypad

Connector for console software: Only CMB-001 cable usable

Display and indicators:

Input display: 7-segment Red LED display 4-digit,
Character size: 10 x 4.6mm (H x W)

Output display: 7-segment Red LED display 4-digit,
Character size: 10 x 4.6mm (H x W)

Power indicator: Green LED

CH1, CH2 indicators: Yellow LED

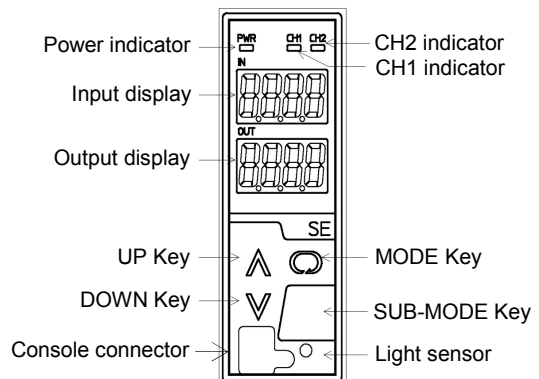

■ Installation Specifications

Power supply: 100 to 240V AC 50/60Hz
 24V AC/DC 50/60Hz
 Allowable voltage range: 85 to 264V AC, 20 to 28V AC/DC
 Power consumption: Approx. 8VA
 Ambient temperature: -5 to 55°C
 Ambient humidity: 35 to 85%RH (non-condensing)
 Mounting: DIN rail
 Dimensions: W30 x H88 x D108mm (including socket)
 Weight: Approx. 190g (including socket)

■ Attached Functions

Light sensor: Automatically measures and controls brightness of the displays, saving energy.
 Power failure countermeasure:
 The data is backed up in non-volatile IC memory.
 Self diagnosis: The CPU is monitored by a watchdog timer, and when an abnormal status is found on the CPU, the unit is switched to warm-up status turning all outputs OFF.

■ Environmental Specifications

RoHS directive compliance

■ Settings

Function Keys

- (1) UP Key: Increases numeric value.
- (2) DOWN Key: Decreases numeric value.
- (3) MODE Key: Selects a setting mode.
- (4) SUB-MODE Key: Lights the displays again when in unlit status. (The UP, DOWN or MODE Key also lights the displays again when in unlit status.)

■ Displays and Indicators

Input display: Indicates the input value.
 Indication of -2000 or less: The minus (-) sign and input value light alternately.
 Indication of 10000 or more: The lower 4 digits flash.
 Under range: "—" flashes on the Input display.
 Over range: "—" flashes on the Input display.
 Warm-up indication:
 For approx. 3 seconds after the power to the instrument is turned on, CH1 input type is indicated on the Input display, and CH2 input type is indicated on the Output display.
 Output display: Indicates the output volume in percentage (%) form.
 Power indicator: A green LED is lit when the power to the instrument is turned on.
 CH1 indicator: A yellow LED is lit when CH1 is selected during [Display selection].
 CH2 indicator: A yellow LED is lit when CH2 is selected during [Display selection].

■ Solderless Terminals

Y Terminal

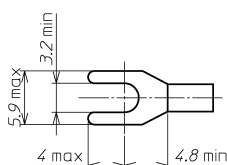

Ring Terminal

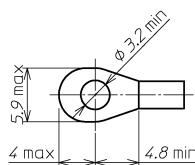

■ Circuit Configuration, Terminal Arrangement

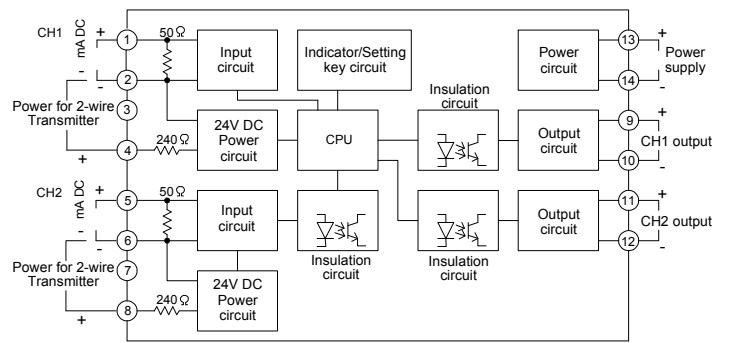

When used as a Current Loop Supply

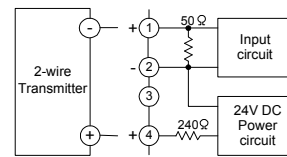

When used as an Isolator

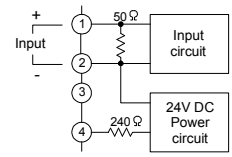

■ External Dimensions (Scale: mm)

