

Current Loop Supply (with indication function)

Model: **SE1D**

Model

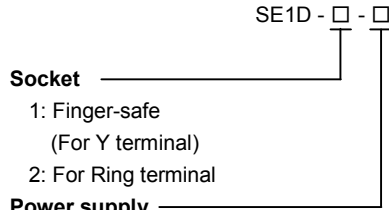

- Socket**
- 1: Finger-safe (For Y terminal)
 - 2: For Ring terminal

- Power supply**
- 0: 100 to 240V AC
 - 1: 24V AC/DC

How to order

Specify the model (e.g.) SE1D-1-0

Default value

Input	4 to 20mA DC
Output	4 to 20mA DC

Accessories (sold separately)

Communication cable for the console software: CMB-001

Input specification

DC current

Connect a shunt resistor (sold separately) between Shunt resistor

Input	Shunt resistor
4 to 20mA DC	50Ω built-in

Output specification

When the output range lower limit is zero, (even if zero adjustment results in a negative value), the output value will not be negative.

DC Current

Output range	Allowable load resistance	Zero adjustment range	Span adjustment range
4 to 20mA DC	700Ω or less	-5 to 5%	95 to 105%
0 to 20mA DC	700Ω or less	0 to 5%	95 to 105%
0 to 12mA DC	1.2kΩ or less	0 to 5%	95 to 105%
0 to 10mA DC	1.2kΩ or less	0 to 5%	95 to 105%
1 to 5mA DC	2.4kΩ or less	-5 to 5%	95 to 105%

DC Voltage

Output range	Allowable load resistance	Zero adjustment range	Span adjustment range
0 to 1V DC	100Ω or more	0 to 5%	95 to 105%
0 to 5V DC	500Ω or more	0 to 5%	95 to 105%
1 to 5V DC	500Ω or more	-5 to 5%	95 to 105%
0 to 10V DC	1kΩ or more	0 to 5%	95 to 105%

Power for 2-wire transmitter

Output voltage: 24 to 28V DC (When load current is 20mA)
 Ripple voltage: Within 200mV DC (When load current is 20mA)
 Max load current: 25mA DC

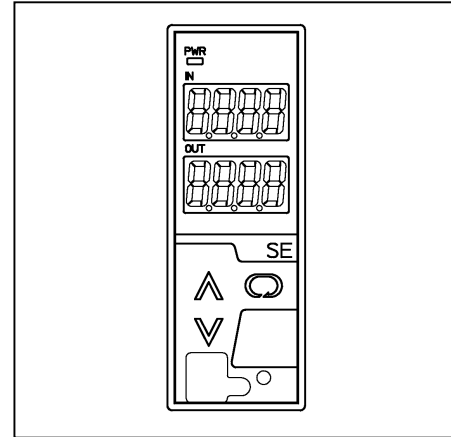

Performance

Accuracy (When ambient temperature is 23°C):

Input (DC current): Within ±0.1%

Output: Within ±0.1%

Indication accuracy: Within input accuracy ±1 digit

Input sampling period: 25ms, 125ms, 250ms (Selectable by keypad)

Response time: 65ms (typ.) (0→90%) (Input sampling period 25ms)

225ms (typ.) (0→90%) (Input sampling period 125ms)

425ms (typ.) (0→90%) (Input sampling period 250ms)

(Selectable by keypad)

Temperature coefficient: ±0.015%/°C or less

Temperature coefficient: ±0.015%/°C or less

Insulation resistance: 10MΩ or more, at 500V DC

(Input – Output – Power supply)

Dielectric strength: 2.0kV AC for 1 minute

(Input – Output – Power supply)

General structure

Case: Frame-resistant resin, Color: Light gray

Front panel: Membrane sheet

Setting: By the front keypad

Connector for console software: Only for CMB-001

Indication: Input display: 7-segment, Red LED display 4-digit

Character size 10×4.6mm (H×W)

Output display: 7-segment, Red LED display 4-digit

Character size 10×4.6mm (H×W)

Power indicator: Green LED

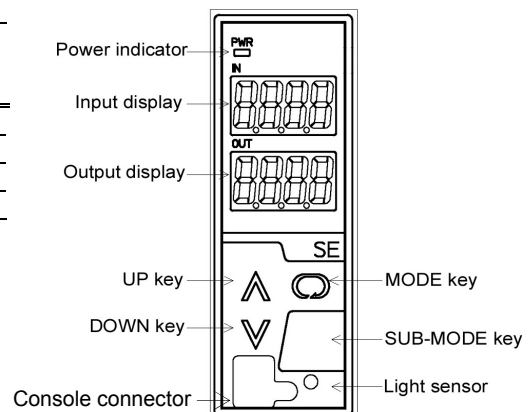

Power supply: 100 to 240V AC 50/60Hz, 24V AC/DC 50/60Hz
 Allowable voltage range: 85 to 264V AC, 20 to 28V AC/DC
 Power consumption : Approx. 8VA
 Ambient temperature: -5 to 55°C
 Ambient humidity: 35 to 85%RH (Non-condensing)
 Mounting: DIN rail mounting
 External dimensions: W30×H88×D108mm (including the socket)
 Weight: Approx. 180g (including the socket)

Attached functions

Auto-light function: Display brightness is controlled in accordance with the surrounding area. Unnecessary brightness is reduced, saving energy.

Power failure countermeasure:

The data is backed up in non-volatile IC memory.

Self diagnosis:

The CPU is monitored by a watchdog timer, and when an abnormal status is found on the CPU, the unit is switched to warm-up status with tuning all outputs off.

Settings

Function keys

- (1) UP Key: Increases the numeric value.
- (2) DOWN Key: Decrease the numeric value.
- (3) MODE Key: Selects the setting mode.
- (4) SUB-MODE Key: Turns the displays ON again when they are in OFF status.
 (The UP, DOWN or MODE Key also turns the displays ON again when they are in OFF status.)

Displays and indicators

Input display: Indicates the input value

Indication of -200.0 or less (for the range with decimal point):

The minus (-) sign and input value light alternately.

Indication of -2000 or less (for DC input):

The minus (-) sign and input value light alternately.

Indication of 10000 or more:

The lower 4 digits flash.

Under range: "----" flashes on the input display.

Over range: "----" flashes on the input display

Warm-up indication: For approx. 3sec. after the power to the instrument is turned on, the input type is indicated on the input display, and Output type is indicated on the Output display.

Output display: Indicates output volume in percentage (%) form.

Power indicator: The green LED lights when the power to the instrument is turned on.

Solderless terminal

Y type

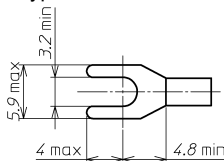

Ring type

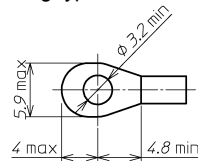

Circuit configuration and terminal arrangement

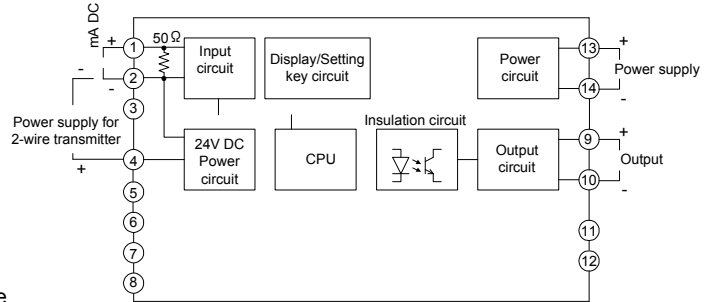

When using as a Current loop supply

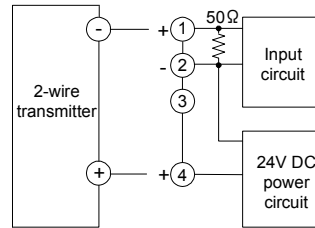

When using as an Isolator

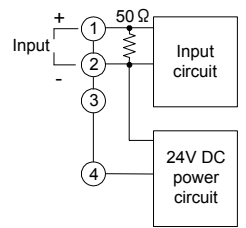

External dimensions (Scale: mm)

