

## ISOLATOR (with indication function)

## MODEL SADC

### Model

SADC-□□-□

Power supply

M: 100 to 240V AC

R: 24V AC/DC

### How to order

Specify a model.

(e.g.) SADC-AA-M

Default value

Input	1 to 5V DC
Output	4 to 20mA DC

### Input specifications

DC current

Input range	Shunt resistor
4 to 20mA DC	50Ω
0 to 20mA DC	
0 to 16mA DC	
2 to 10mA DC	100Ω
0 to 10mA DC	
1 to 5mA DC	200Ω
0 to 1mA DC	1kΩ

Connect a shunt resistor (sold separately) between input terminals.

### Input specifications

DC voltage

Input range	Input resistance	Allowable signal source resistance
0 to 10mV DC	1MΩ	20Ω or less
-10 to 10mV DC		40Ω or less
0 to 50mV DC		200Ω or less
0 to 60mV DC		
0 to 100mV DC		
0 to 1V DC		
0 to 5V DC		2kΩ or less
1 to 5V DC		1kΩ or less
0 to 10V DC		

### Output specifications

#### Output 1 (Universal)

When the output range lower limit is zero, (even if zero adjustment results in a negative value), the output value will not be negative.

DC current

Output range	Allowable load resistance	Zero adjustment range	Span adjustment range
4 to 20mA DC	700Ω or less	-5 to 5%	95 to 105%
0 to 20mA DC	700Ω or less	0 to 5%	95 to 105%
0 to 12mA DC	1.2kΩ or less	0 to 5%	95 to 105%
0 to 10mA DC	1.2kΩ or less	0 to 5%	95 to 105%
1 to 5mA DC	2.4kΩ or less	-5 to 5%	95 to 105%

DC voltage

Output range	Allowable load resistance	Zero adjustment range	Span adjustment range
0 to 1V DC	100Ω or more	0 to 5%	95 to 105%
0 to 5V DC	500Ω or more	0 to 5%	95 to 105%
1 to 5V DC	500Ω or more	-5 to 5%	95 to 105%
0 to 10V DC	1kΩ or more	0 to 5%	95 to 105%

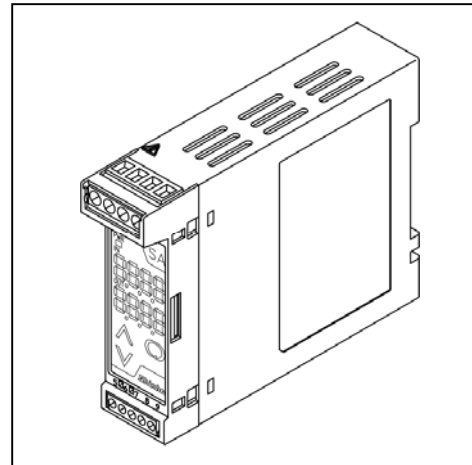

### Performance

Accuracy:

• Input : Within ±0.1%

• Output : Within ±0.1%

Display accuracy:

Within input accuracy ±1 digit

Response time: 0.5 sec. (typical) (0 → 90%)

Temperature coefficient: ±0.015%/°C

Insulation resistance: 10MΩ or more, at 500V DC  
(Input - Output - Power)

Dielectric strength: 2.0kV AC for 1 minute  
(Input - Output - Power)

### General structure

Case : Flame-resistant resin Color: Light gray

Front panel: Membrane sheet

Setting : By the front keypad

Indication : Input display:

7-segment, Red LED display 4-digit

Character size, 7.4 x 4.0mm (H x W)

Output display:

7-segment, Green LED display 4-digit

Character size, 7.4 x 4.0mm (H x W)

Power indicator: Green LED

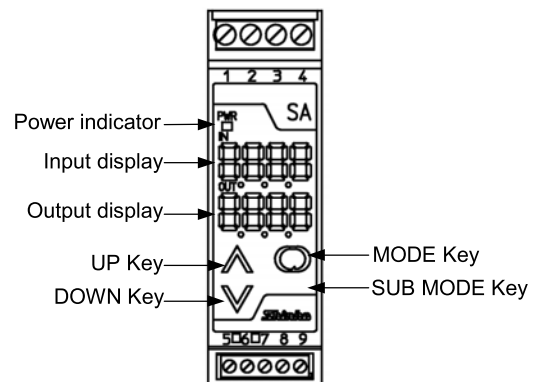

# SA series

## ■ Installation specifications

Power supply	: 100 to 240V AC 50/60Hz 24V AC/DC 50/60Hz
Allowable voltage range:	85 to 264V AC 20 to 28V AC/DC
Power consumption	: Approx. 6VA
Ambient temperature	: -5 to 55°C
Ambient humidity	: 35 to 85%RH (non-condensing)
Weight	: Approx. 120g
Mounting	: DIN rail mounting
External dimensions	: 22.5 (W) x 75 (H) x 100 (D)mm

## ■ Attached functions

Power failure countermeasure:

The data is backed up in non-volatile IC memory.

Self diagnosis:

The CPU is monitored by a watchdog timer, and when an abnormal status is found on the CPU, the unit is switched to warm-up status turning all outputs off.

## ■ Environmental specification

RoHS directive compliance

## ■ Settings

Function keys

- (1) UP Key : Increases the numeric value.
- (2) DOWN Key : Decreases the numeric value.
- (3) MODE Key : Selects the setting mode.
- (4) SUB MODE Key: Press with the MODE Key to select the setting mode.

Setting items

Set by pressing the MODE Key for 3 seconds

- (1) Output zero adjustment
- (2) Output span adjustment

Set by the MODE Key and SUB MODE Key

- (1) Set value lock
- (2) Input range
- (3) Decimal point place
- (4) Output 0% value
- (5) Output 100% value
- (6) Filter time constant
- (7) Sensor correction
- (8) Output type/range
- (9) Output Normal/Reverse
- (10) Display selection
- (11) Indication time

## ■ Displays and indicators

Input display : Indicates the input value.

Indication of -2000 or less:  
The minus (-) sign and input value light alternately.

Indication of 10000 or more:  
The lower 4 digits flash.

Under range: “- - - -” flashes on the Input display.

Over range : “- - - -” flashes on the Input display.

Warm-up indication:

For approx. 3 seconds after the power to the instrument is turned on, the input type is indicated on the Input display, and the Output type is indicated on the Output display.

Output display : Indicates the output volume in percentage (%) form.

Power indicator : The green LED lights when the power to the instrument is turned on.

## ■ Ferrules

Terminals from 1 to 4

Insulation sleeve attached (Phoenix Contact GMBH & CO.)

AI0.25-8YE	0.2 – 0.25mm <sup>2</sup>
AI0.34-8TQ	0.25 – 0.34mm <sup>2</sup>
AI0.5-8WH	0.34 – 0.5mm <sup>2</sup>
AI0.75-8GY	0.5 – 0.75mm <sup>2</sup>
AI1.0-8RD	0.75 – 1.0mm <sup>2</sup>
AI1.5-8BK	1.0 – 1.5mm <sup>2</sup>

Crimping pliers (Phoenix Contact GMBH & CO.)

CRIMPFOX ZA3  
CRIMPFOX UD6

Terminals from 5 to 9

Insulation sleeve attached (Phoenix Contact GMBH & CO.)

AI0.25-8YE	0.2 – 0.25mm <sup>2</sup>
AI0.34-8TQ	0.25 – 0.34mm <sup>2</sup>
AI0.5-8WH	0.34 – 0.5mm <sup>2</sup>

Crimping pliers (Phoenix Contact GMBH & CO.)

CRIMPFOX ZA3  
CRIMPFOX UD6

## ■ Circuit configuration, terminal arrangement

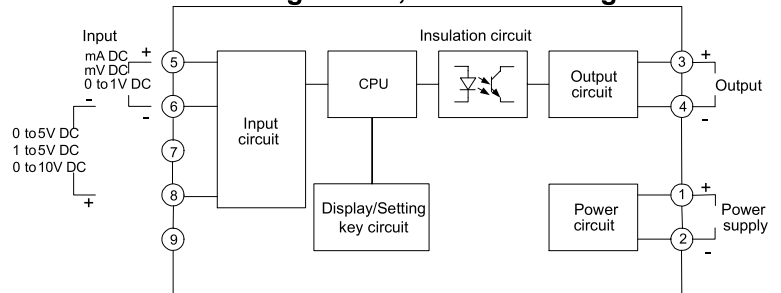

## ■ External dimensions (Scale: mm)

